

# BULL 424 ANZ 624 ANZ

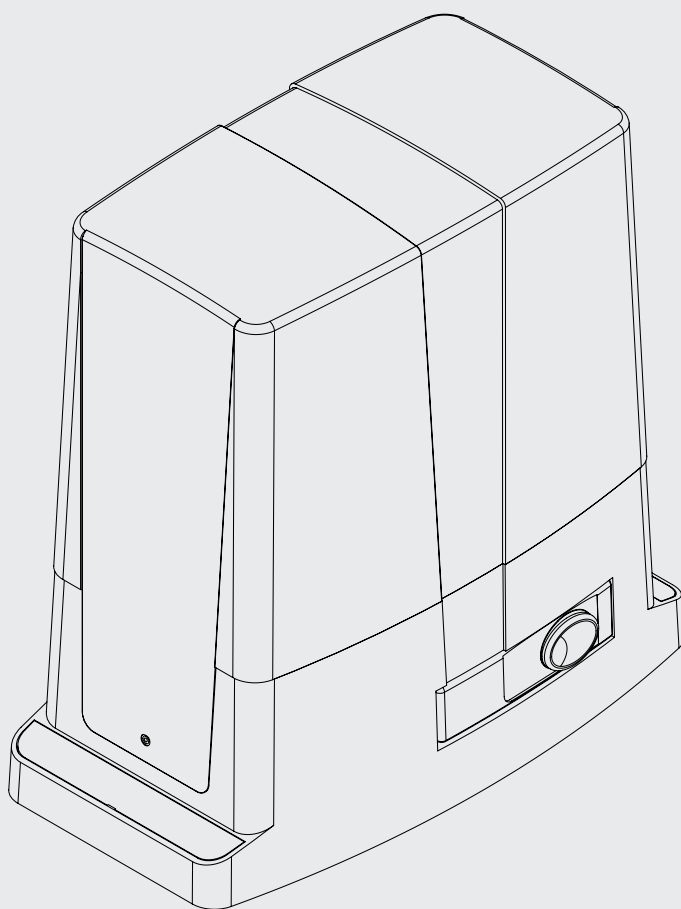

**BENINCA**<sup>®</sup>  
TECHNOLOGY TO OPEN





1

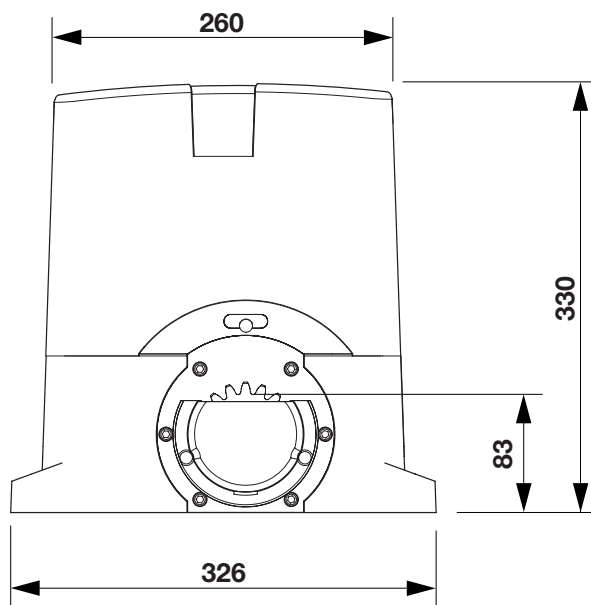
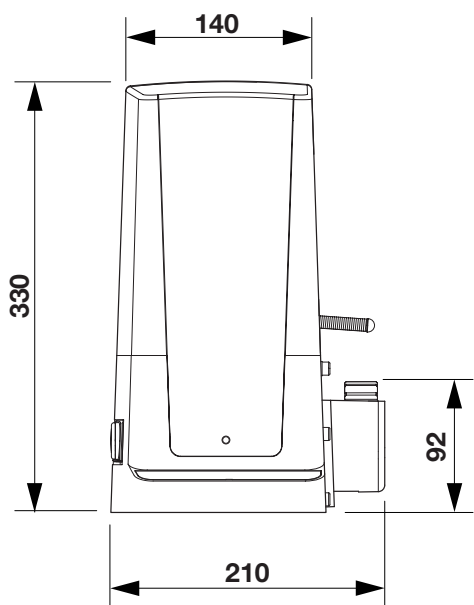

2

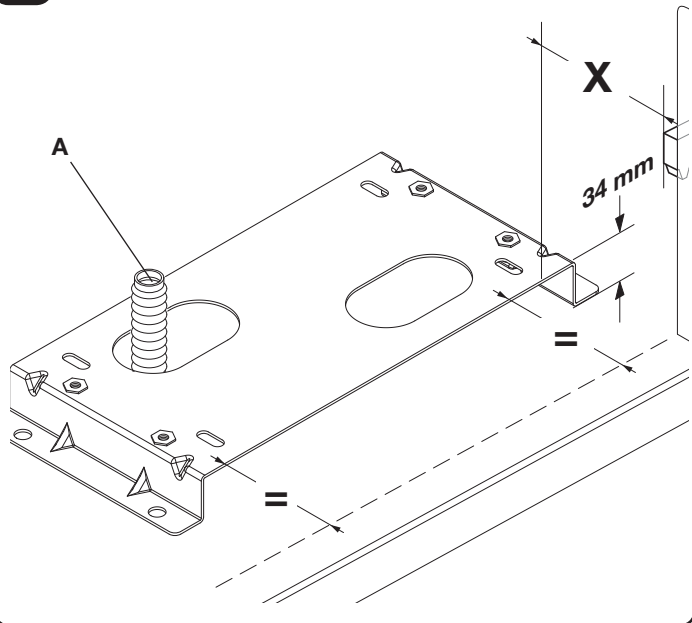

3

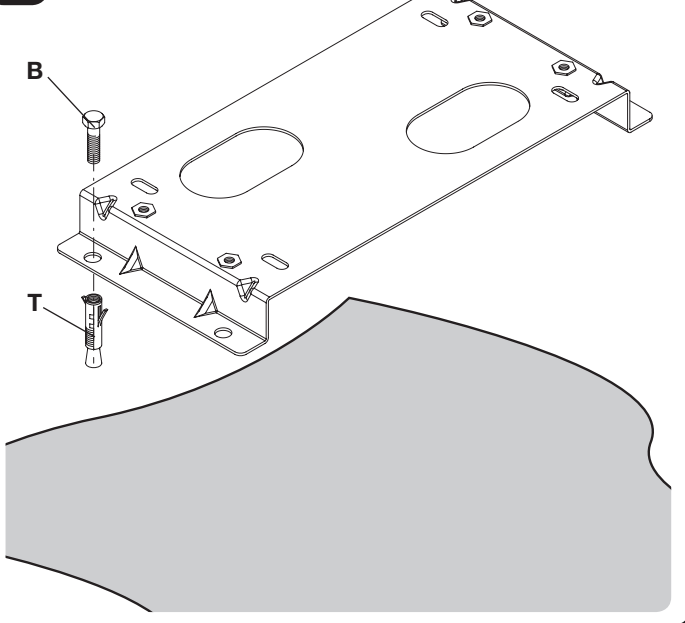

4

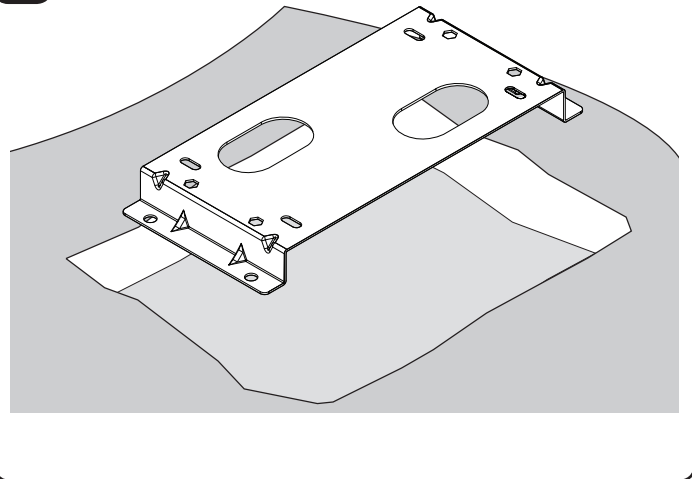

5

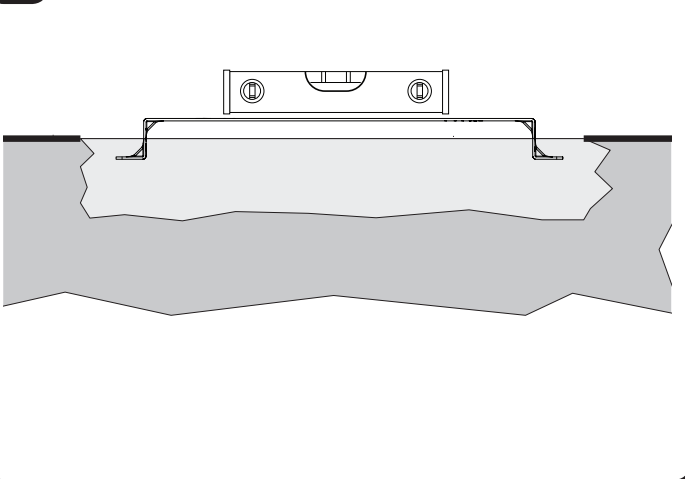

6

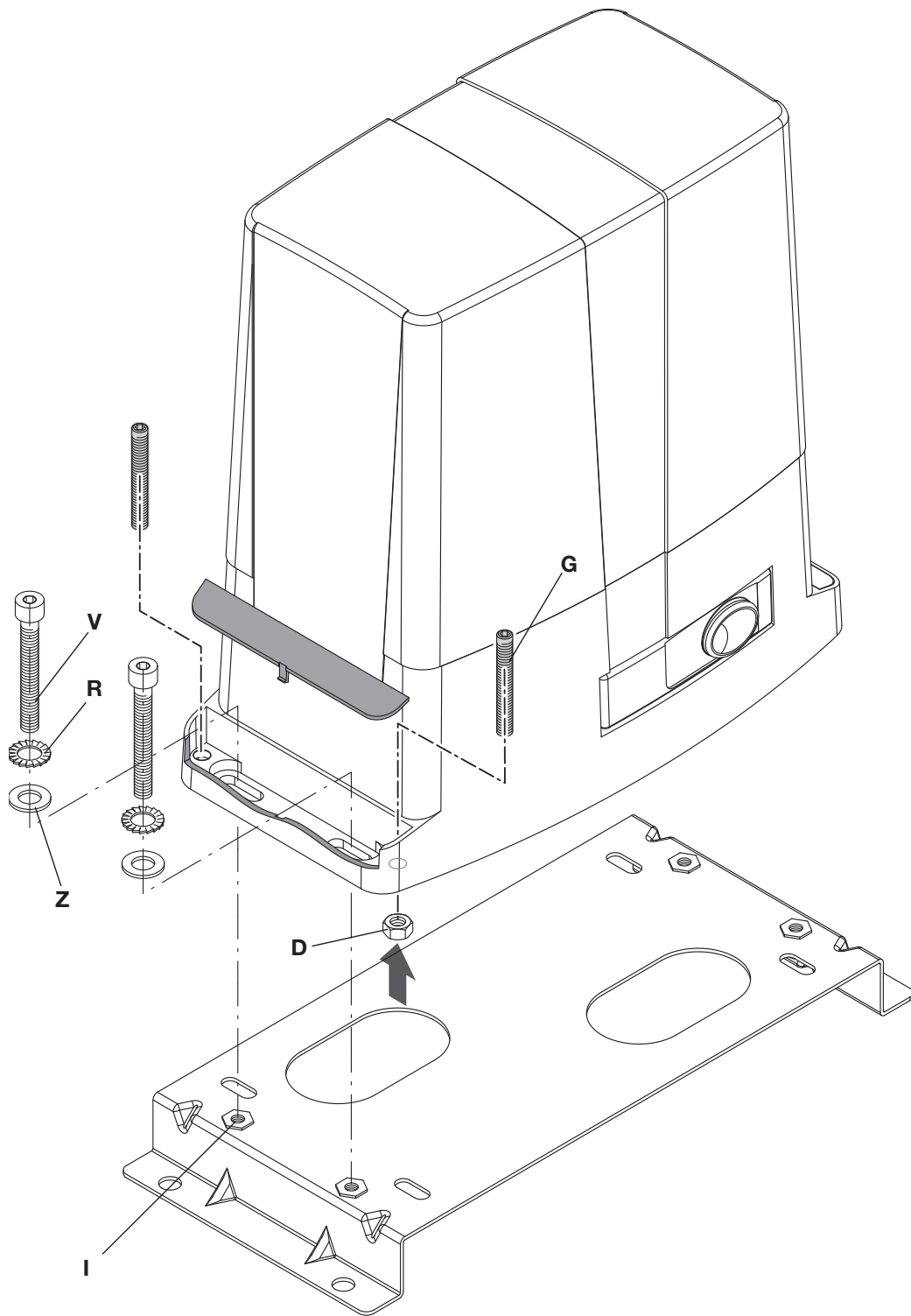

7

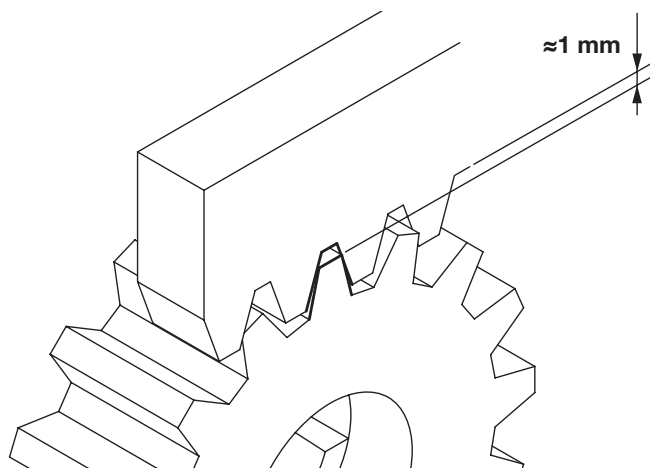

8

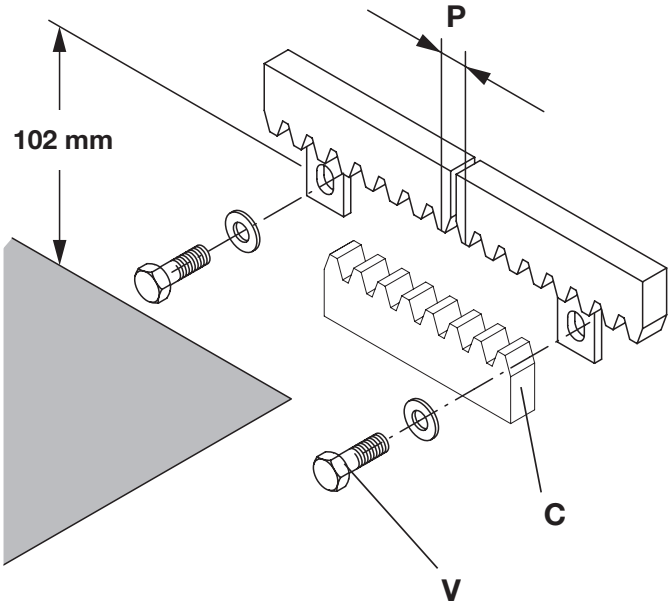

9

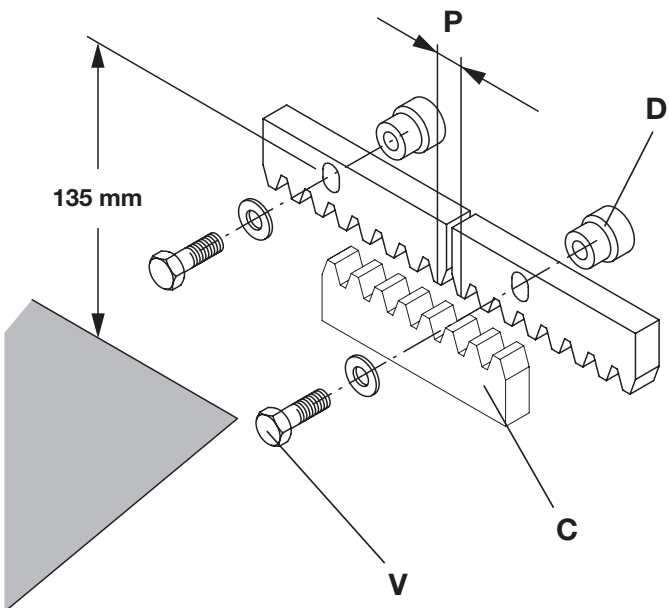

10

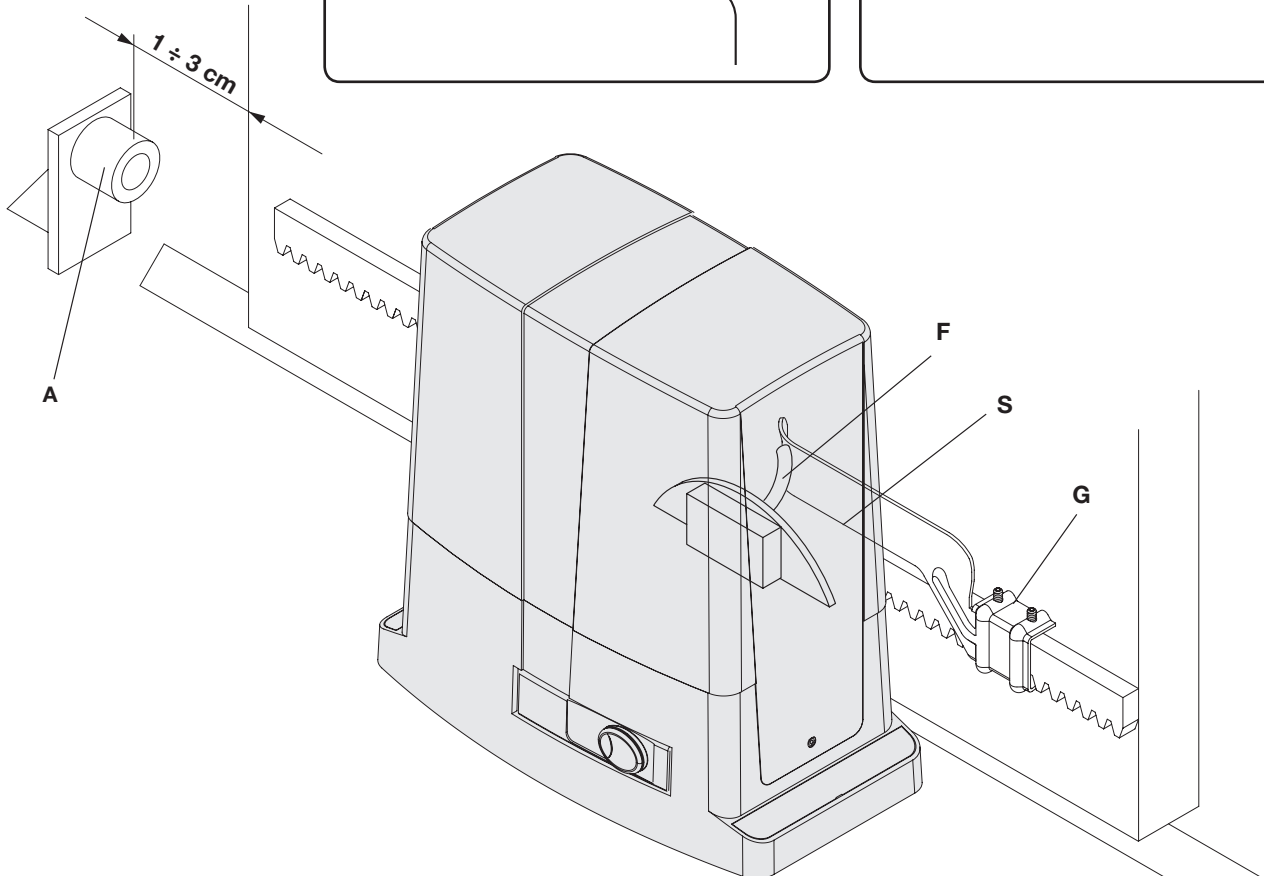
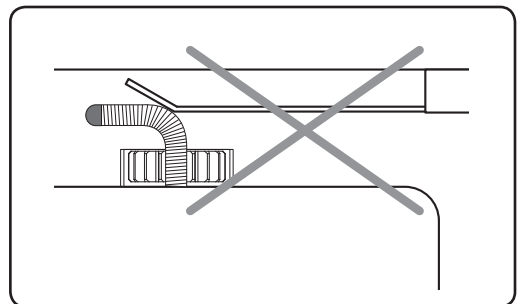
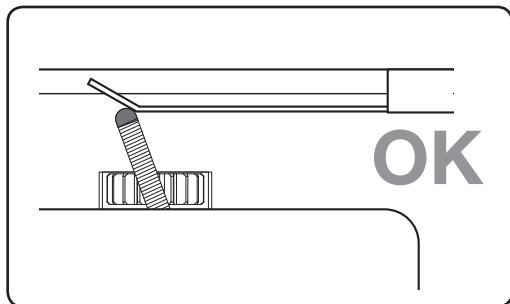



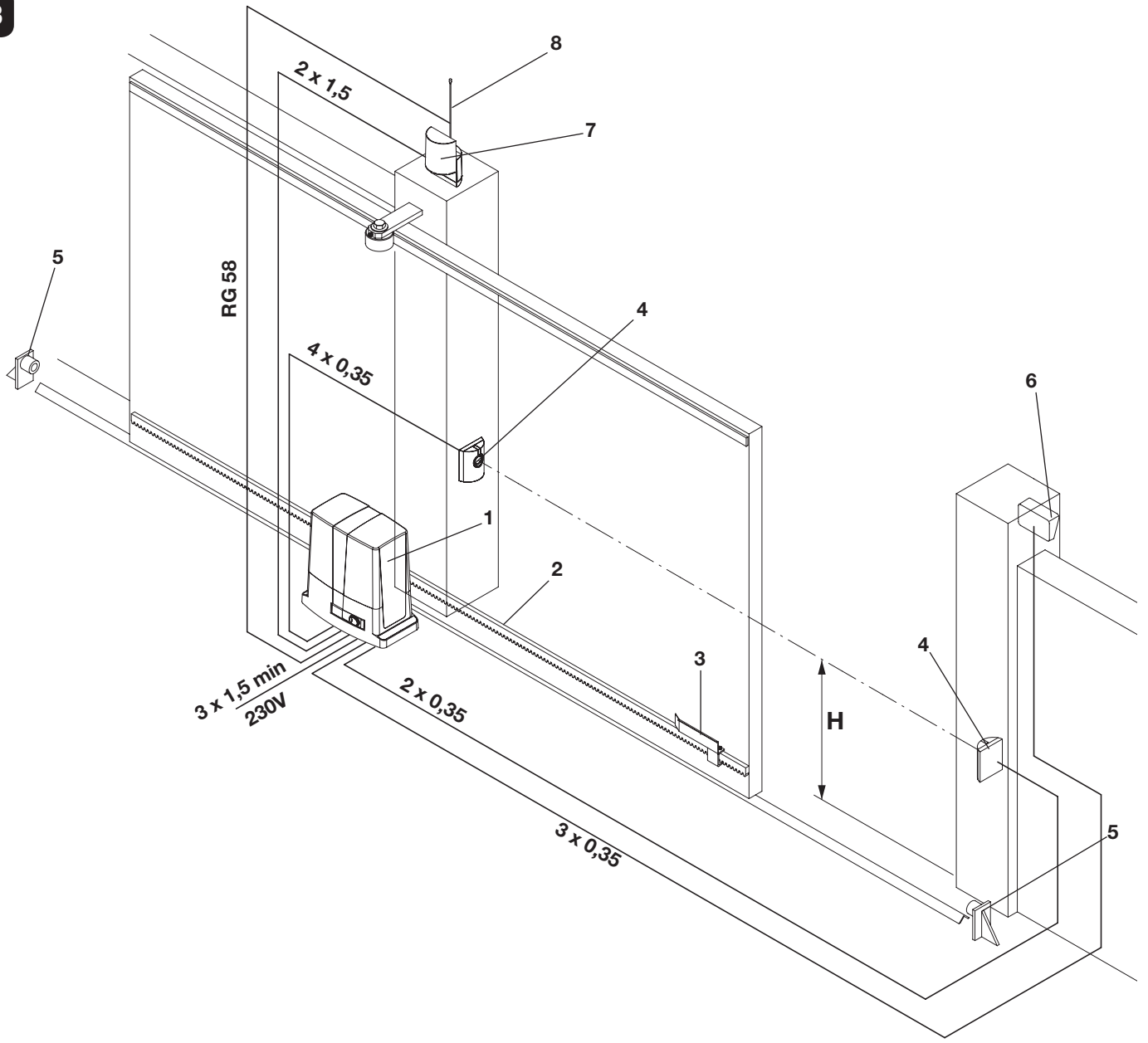



The product shall not be used for purposes or in ways other than those for which the product is intended for and as described in this manual. Incorrect uses can damage the product and cause injuries and damages. The company shall not be deemed responsible for the non-compliance with a good manufacture technique of gates as well as for any deformation, which might occur during use. Keep this manual for further use.



This manual has been especially written to be use by qualified fitters. Installation must be carried out by qualified personnel (professional installer, according to EN 12635), in compliance with Good Practice and current code. Make sure that the structure of the gate is suitable for automation. The installer must supply all information on the automatic, manual and emergency operation of the automatic system and supply the end user with instructions for use.



Packaging must be kept out of reach of children, as it can be hazardous. For disposal, packaging must be divided the various types of waste (e.g. carton board, polystyrene) in compliance with regulations in force. Do not allow children to play with the fixed control devices of the product. Keep the remote controls out of reach of children. This product is not to be used by persons (including children) with reduced physical, sensory or mental capacity, or who are unfamiliar with such equipment, unless under the supervision of or following training by persons responsible for their safety. Apply all safety devices (photocells, safety edges, etc.) required to keep the area free of impact, crushing, dragging and shearing hazard. Bear in mind the standards and directives in force, Good Practice criteria, intended use, the installation environment, the operating logic of the system and forces generated by the automated system. Installation must be carried out using safety devices and controls that meet standards EN 12978 and EN 12453. Only use original accessories and spare parts, use of non-original spare parts will cause the warranty planned to cover the products to become null and void. All the mechanical and electrical parts composing automation must meet the requirements of the standards in force and outlined by CE marking.



An omnipolar switch/section switch with remote contact opening equal to, or higher than 3mm must be provided on the power supply mains. Make sure that before wiring an adequate differential switch and an overcurrent protection is provided. Pursuant to safety regulations in force, some types of installation require that the gate connection be earthed. During installation, maintenance and repair, cut off power supply before accessing to live parts. Also disconnect buffer batteries, if any are connected. The electrical installation and the operating logic must comply with the regulations in force. The leads fed with different voltages must be physically separate, or they must be suitably insulated with additional insulation of at least 1 mm. The leads must be secured with an additional fixture near the terminals. During installation, maintenance and repair, interrupt the power supply before opening the lid to access the electrical parts. Check all the connections again before switching on the power. The unused N.C. inputs must be bridged.



#### WASTE DISPOSAL

As indicated by the symbol shown, it is forbidden to dispose this product as normal urban waste as some parts might be harmful for environment and human health, if they are disposed of incorrectly. Therefore, the device should be disposed in special collection platforms or given back to the reseller if a new and similar device is purchased. An incorrect disposal of the device will result in fines applied to the user, as provided for by regulations in force.

*Descriptions and figures in this manual are not binding. While leaving the essential characteristics of the product unchanged, the manufacturer reserves the right to modify the same under the technical, design or commercial point of view without necessarily update this manual.*

## 1) INTRODUCTION

Congratulations on your choice of a BULL gear motor.

All items included in Benincà's wide product range stem from twenty year of our experience in the sector of automatic systems, always striving to find new materials and advanced technologies.

For this reason, nowadays we are able to offer you extremely reliable products that, thanks to their power, efficiency and long-lasting features, entirely meet the end user's requirements.

All our products are covered by a guarantee.

Furthermore, an R.C. insurance policy signed with a primary insurance company, covers any injuries or damages caused by manufacturing faults.

## 2) GENERAL INFORMATION

This automatic system, with 24VDC single-phase power supply for sliding gates, is available in the following versions:

BULL 424 for gates with maximum weight equal to 350kg

BULL 624 for gates with maximum weight equal to 600kg

BULL is a monobloc system featuring a refined design and reduced dimensions. The motor and an irreversible reduction system, manufactured with high resistant materials, are housed in an aluminium container. BULL is equipped with spring limit switches. The customised key emergency release allows to open and close the gate in case of power failure.

Anti-crash safety is ensured by an electronic device (encoder and amperometric sensor) which detects any obstacle present.

## 3) PRELIMINARY CHECKS

For a good operation of the automatic system for sliding gates, the gate or door shall meet the following features:

- the track and relevant wheels must feature correct sizes and must undergo adequate maintenance (in order to avert excessive friction during the sliding of the gate).
- during operation, the door shall not excessively oscillate.
- a mechanical stopper (according to regulations in force) shall limit the opening and closing movements.

## 4) SPECIFICATIONS

	BULL 424 ANZ	BULL 624 ANZ
Power supply	230Vac 50Hz	
Power supply, motor	24Vdc	
Current drawn	0,4 A	0,5 A
Torque	12 Nm	24 Nm
Work jogging	(intensive use)	
Protection level	IP44	
Insulation Class	F	
Operating temperature	-20°C / +50°C	
Gate max. weight	350kg	600kg
Rack module	M4	
Opening speed	11 m/min	9.75 m/min
Noise	<70 dB	
Lubrication	CASTROL OPTITEMP LP2	
Weight	10,2 kg	11,6 kg



## 5) INSTALLATION (FIG.1)

Overall dimensions of the gear motor expressed in mm.

### 5.1) FITTING OF THE RACK

#### Rack in nylon (Fig.8).

Position the rack at a height of 102 mm from the centre line of the fixing slot provided on the base on which the foundation plate will be fitted. At that height, drill a hole on the gate and provide for a M6 threading.

Keep to the P tooth pitch, even from a section of rack and another. To this purpose, it could be useful to join another section of rack (Part. C)

*Then fix the rack with V screws, taking care, once the actuator is installed, that 1-mm backlash is left between the rack and the tow wheel (see Fig.7). To this purpose, use the slots on the rack.*

#### Rack in Fe 12x30mm (Fig.9).

Position the spacers D by welding them or fitting them with screws to the gate, at 135 mm height from the centre line of the fixing slot provided on the base on which the foundation plate will be fitted. Fix the rack.

Keep to the P tooth pitch, for all sections of the rack. To this purpose, it could be useful to connect another section of rack (Part. C)

*Then fix the rack with V screws, taking care, once the actuator is installed, that 1-mm backlash is left between the rack and the tow wheel (see Fig.7). To this purpose, use the slots on the rack.*

### 5.2) POSITIONING OF THE FOUNDATION PLATE (FIG.5-6)

It is very important to keep to dimension X shown in Fig.2. This value depends on the type of rack used:

X = 11 mm for rack in nylon

X = 13 mm for rack in iron, 12x30mm

Preset a corrugated tube (Fig.2 -A) for the passage of power supply cables and connection wires for the accessories.

Check that, at the end of the fitting, the foundation plate is perfectly parallel with respect to the wing.

#### Fitting with screw anchors on cement base (fig. 3)

Through 4 "T" screw anchors in steel (not supplied), firmly anchor the foundation plate to ground by means of 4 bolts "B" (not supplied). Use the foundation plate as drilling template.

Fix the geared motor to the plate by means of the 4 screws V (M10x70), with the relevant plain washers R and knurled washers, as indicated in the figure 6.

#### Installation with cement (fig. 4-5)

In this case, after providing for an adequate foundation hole, pour cement on the plate, taking care of the plate level. Check that the threaded inserts (I) for the fitting screws are clean and cement free.

Wait for the hardening of the cement.

Fix the geared motor to the plate by means of the 4 screws V (M10x70), with the relevant plain washers R and knurled washers, as indicated in the figure 6.

#### Height adjustment of the geared motor

The height of the geared motor (10mm max) can be adjusted in height, with respect to the foundation base, by 4 dowels G.

In this case, BEFORE fitting the geared motor to the plate, apply the 4 adjustment dowels G, by inserting the 4 nuts D in the special housings located at the bottom of the geared motor.

Then adjust the 4 dowels by lifting the geared motor at the desired height. Fix the motor by firmly tighten the 4 screws V4 (M10x70) and related flat washers R and knurled washers Z, as shown in the figure 6.

### 5.3) POSITIONING OF THE LIMIT SWITCH BRACKETS (FIG.10)

Manually open the gate and leave a clearance from 1 to 3cm according to the weight of the gate between the main door and the mechanical stopper A. Fix the bracket to the limit switch S by using the grains G, so that the limit switch microswitch F is pressed. The same operation should be repeated with gate in the closing phase.

N.B.: The limit switch bracket should be positioned so that the gate can be stopped without hitting the mechanical stopper.

## 6) MANUAL OPERATION (FIG.11)

Should a power failure or malfunction occurs, to manually operate the gate proceed as follows:

- After inserting the customised key C, turn it anti-clockwise and pull the lever L.
- The gear motor is unlocked and the gate can be moved by hand.
- To return to the normal operating mode, close the lever L again and manually activate the gate until it is geared.

## 7) WIRE DIAGRAM (FIG.13)

For the wire connections of the system and to adjust the operating modes, please refer to the Instruction Manual of the control unit.

**In particular, the anti-crash device (encoder) should be adjusted ac-**

**ording to regulations in force.**

**Please remember that the device should be earthed by means of the appropriate terminal.**

Fig.10 shows wiring for a standard installation. Before proceeding to wiring, check that the type of cables used is consistent with those required for accessories.

Dimension H stands for the installation height of photocells. A clearance between 40 and 60 cm is advisable.

Key of components:

- 1 Gear motor with incorporated BULL control unit
- 2 M4 rack, Nylon/Fe
- 3 Limit switch brackets
- 4 Photocells
- 5 Mechanical stoppers
- 6 Key selector or digital keyboard
- 7 Flashing light
- 8 Antenna

## 8) BUFFER BATTERIES (FIG.12)

An optional kit of buffer batteries BULL24.CB is available. This permits the operation of the system also in case of power failure.

The batteries can be installed inside the gear motor, fixed through a bracket on the rear of the container of the control unit, as shown in Fig.14.

For further information, please see instructions supplied with the product.

## WARNING

The RC product insurance policy, which covers any injuries or damages to objects caused by manufacturing defects, requires the use of Benincà's original accessories.

### SAFETY MEASURES

- Do not stand within the gate movement area.
- Children must not play with controls and near the gate.
- In the event of malfunctions, do not attempt to repair the failure but contact the specialised personnel.

### MANUAL AND EMERGENCY MANOEUVRE

In the event of power failure or malfunction, to manually operate the gate proceed as follows:

- After inserting the customized key C, turn it anti-clockwise and pull the lever L.
- The geared motor is unlocked and the gate can be moved by hand.
- To return to the normal operating mode, close the lever L again and manually activate the gate until it is geared.

### MAINTENANCE

- Every month check the good operation of the emergency manual release.
- It is mandatory not to carry out extraordinary maintenance or repairs as accidents may be caused. These operations must be carried out by qualified personnel only.
- The operator is maintenance free but it is necessary to check periodically if the safety devices and the other components of the automation system work properly. Wear and tear of some components could cause dangers.

### WASTE DISPOSAL



As indicated by the symbol shown, it is forbidden to dispose this product as normal urban waste as some parts might be harmful for environment and human health, if they are disposed of incorrectly. Therefore, the device should be disposed in special collection platforms or given back to the reseller if a new and similar device is purchased. An incorrect disposal of the device will result in fines applied to the user, as provided for by regulations in force.

### WARNING

All Benincá products are covered by insurance policy for any possible damages to objects and persons caused by construction faults under condition that the entire system be marked CE and only Benincá parts be used.

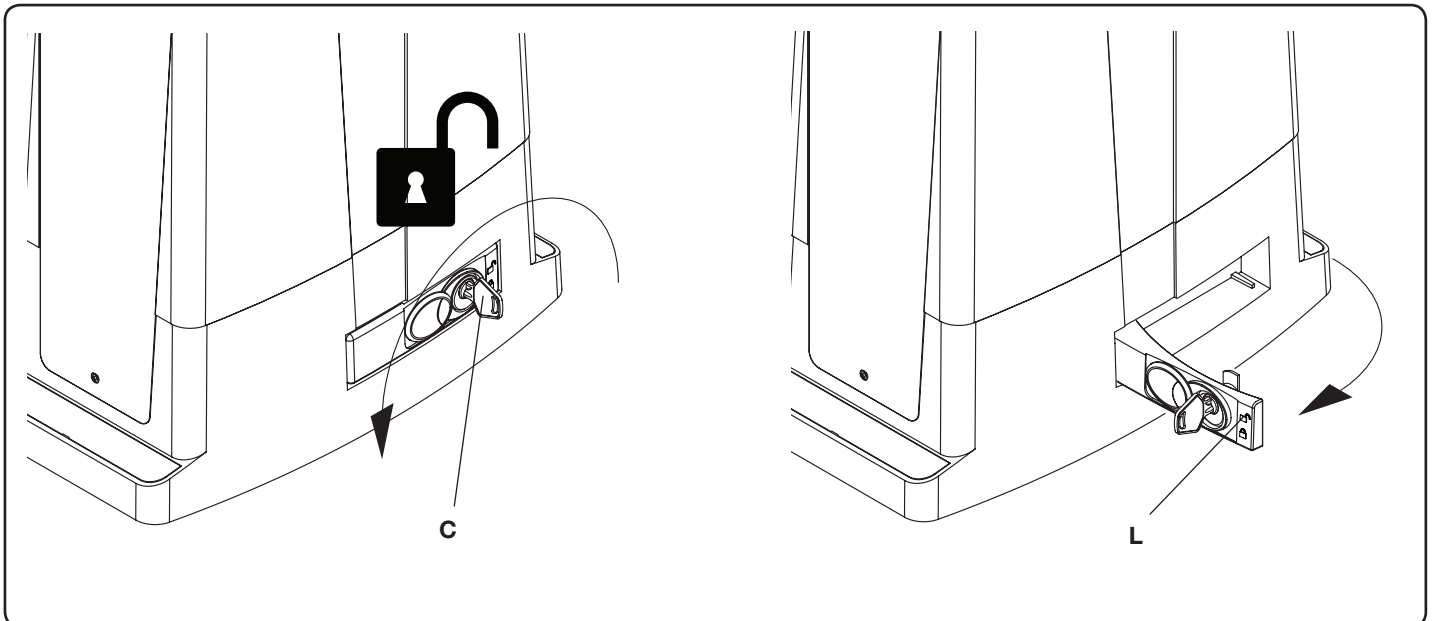

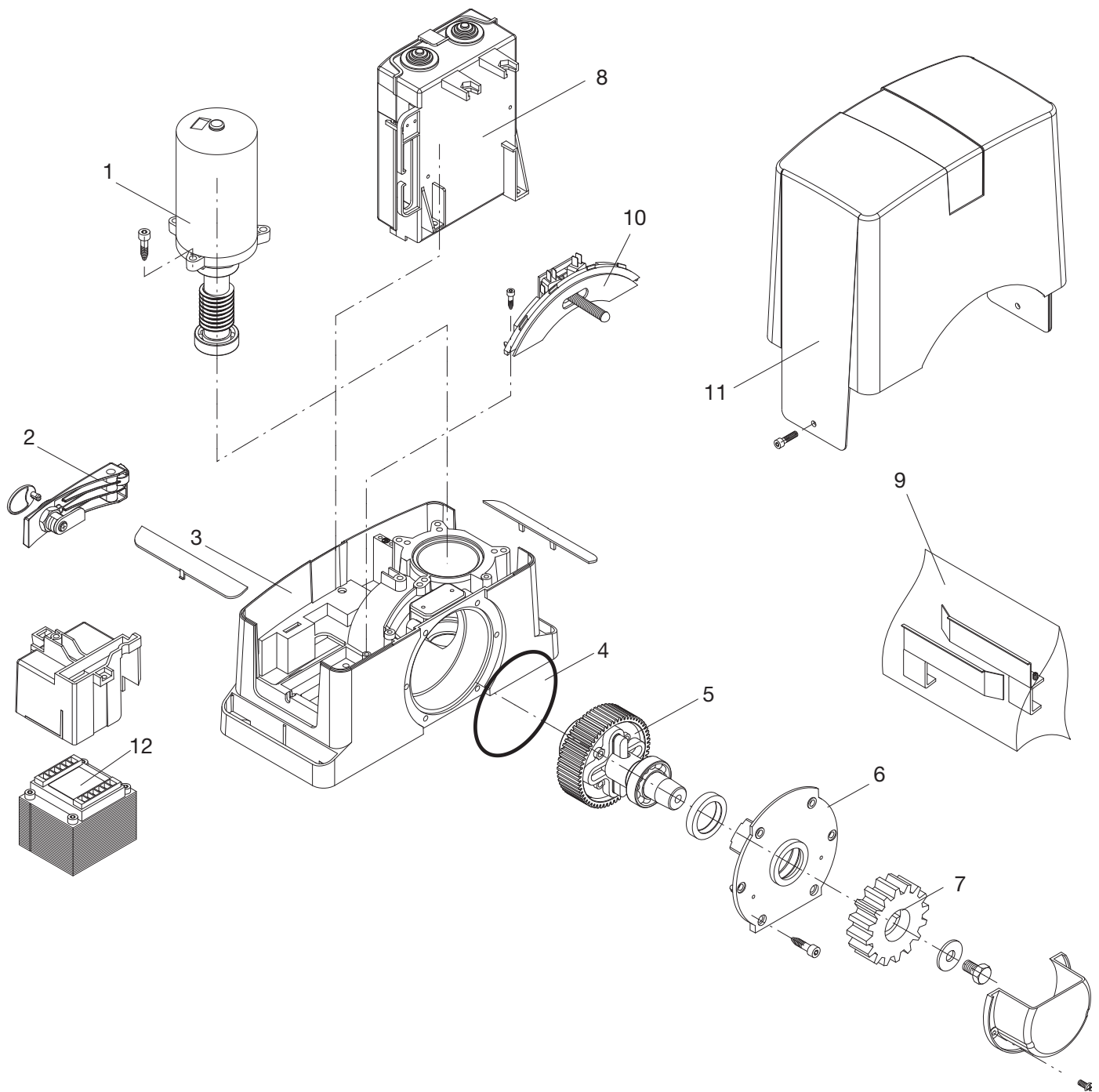

Ref.	BULL 424 ANZ Code	Note
1	9686416	
2	9686688	
3	9686689	
4	9686421	
5	9686422	
6	9686690	
7	9686414	
8	968600681	
9	9686691	
10	9686329	
11	9686427	
12	9686692	

Ref.	BULL 624 ANZ Code	Note
1	9686477	
2	9686328	
3	9686420	
4	9686421	
5	9686423	
6	9686424	
7	9686414	
8	968600681	
9	9686691	
10	9686329	
11	9686427	
12	9686692	

**BENINCA<sup>®</sup>**

**AUTOMATISMI BENINCÀ** SpA - Via Capitello, 45 - 36066 Sandrigo (VI) - Tel. 0444 751030 r.a. - Fax 0444 759728

---